

AKZU Installation instruction for Sprite X2 series Surface mounting

Warning and safety instructions

1. Only interior using for this type of luminaire.
2. Main voltage supply must be disconnected or switched off before installation, uninstal or cleaning.
3. Use the enclosed protective gloves when handling the reflector, if applicable.
4. Ensure there is enough space for heat dissipation of the luminaire, do not place anything in 10cm around the luminaire. The luminaire must not under any circumstance be covered with heat insulating materials.
5. The luminaire must not be installed on inflammable parts of building.
6. Keep object out of the required minimum distance along the optical axis of the light source.
7. Please refer to the specific installation instructions, the label or imprint on the luminaire for information concerning any restrictions relating to the use of luminaire, type of installation and etc.
8. If necessary the ceiling should be reinforced at the supporting points of the mounting frame or bracket.
9. The luminaire must only be operated with control gear matching the LED module provided or recommended by AKZU. No liability is accepted if used with other control gears.
10. When installing, always observe relative local rules and regulations.

Limitations

Our warranty is contingent upon the observance of this product information, in particular, it shall be void if the fitting instructions are not followed, the fitting dimensions are not observed, or any modification is made to the luminaire.

Cleaning

1. Luminaires should be cleaned regularly to make sure its working in good condition.
2. Disconnect the power and wait it is cooled down before cleaning.
3. Use soft cloths to clean.
4. Use litmusless detergent.
5. Do not use rigid, sharp, frictional or similar material or tool to clean
6. Do not use acidic, alkaline, ethanol or similar chemicals to clean.

All data, images,
and specifications
are for reference only and
may be changed due to
product improvement
without prior notice.

More details at
www.akzu.com

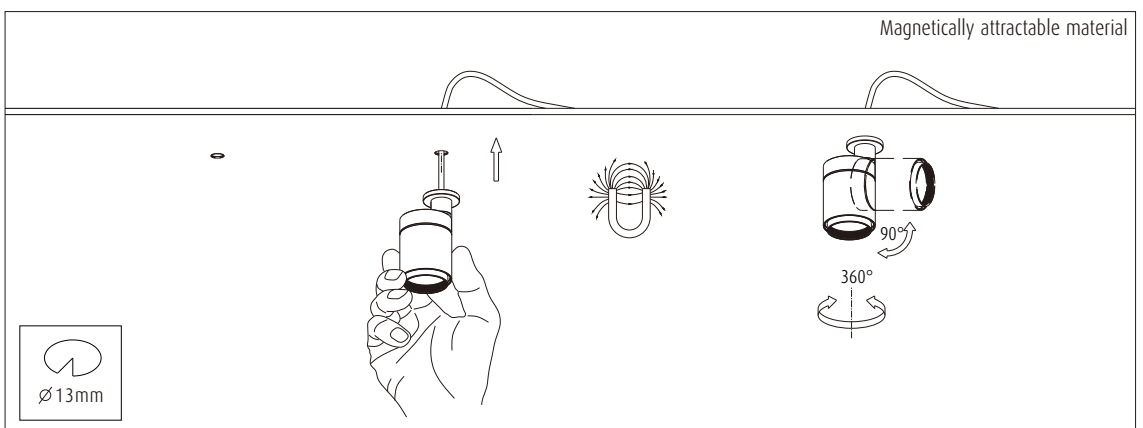
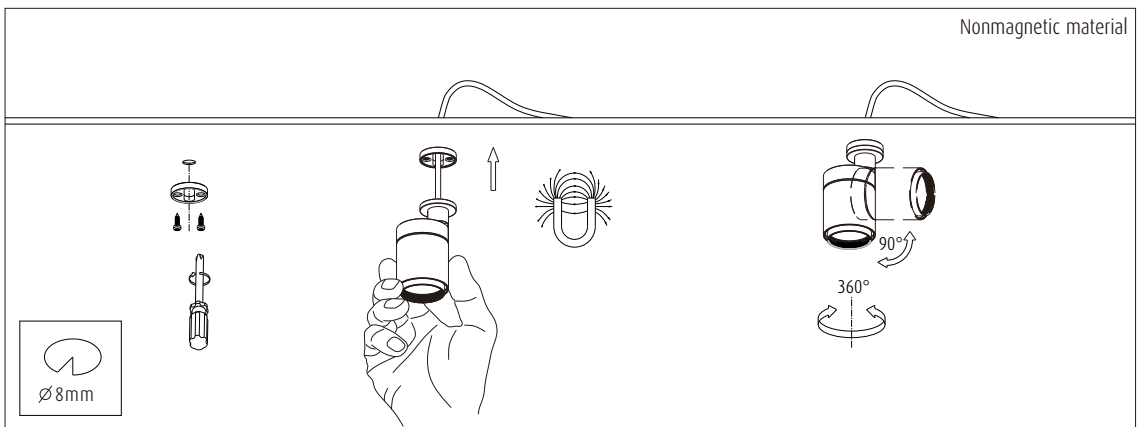
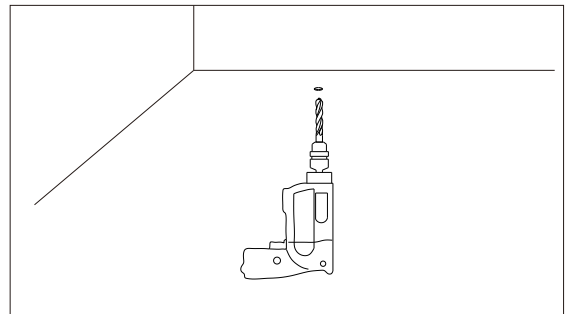
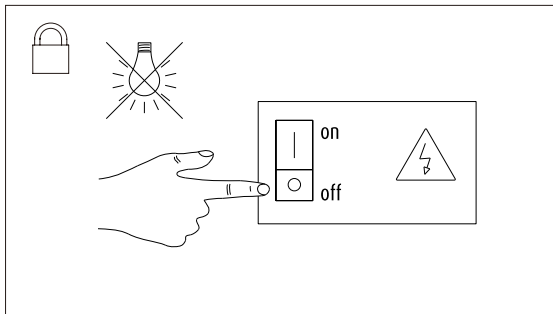
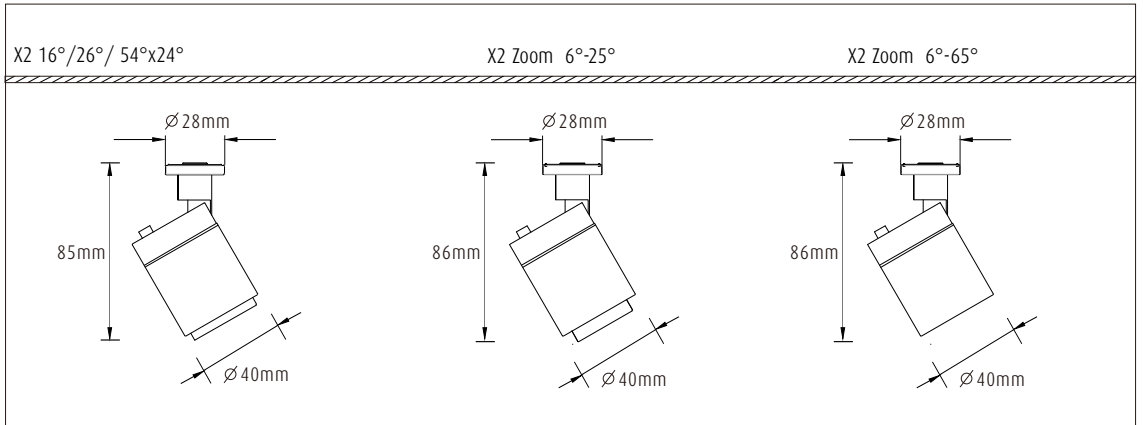
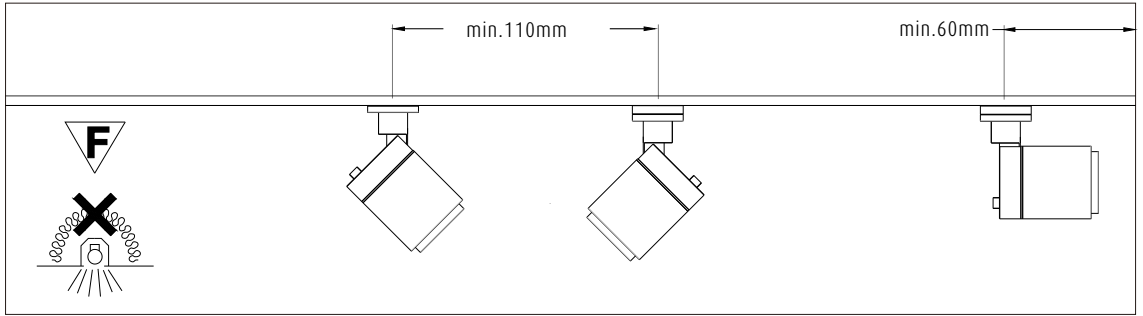

All data, images, and specifications are for reference only and may be changed due to product improvement without prior notice.

More details at www.akzu.com

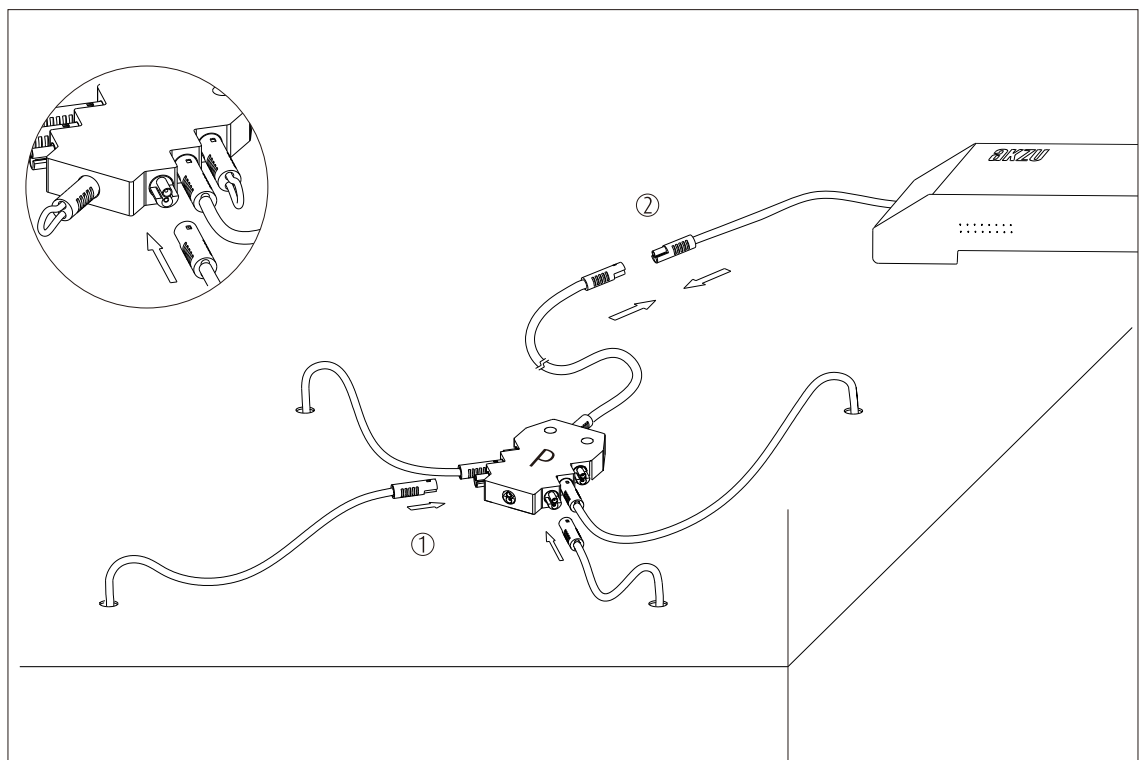
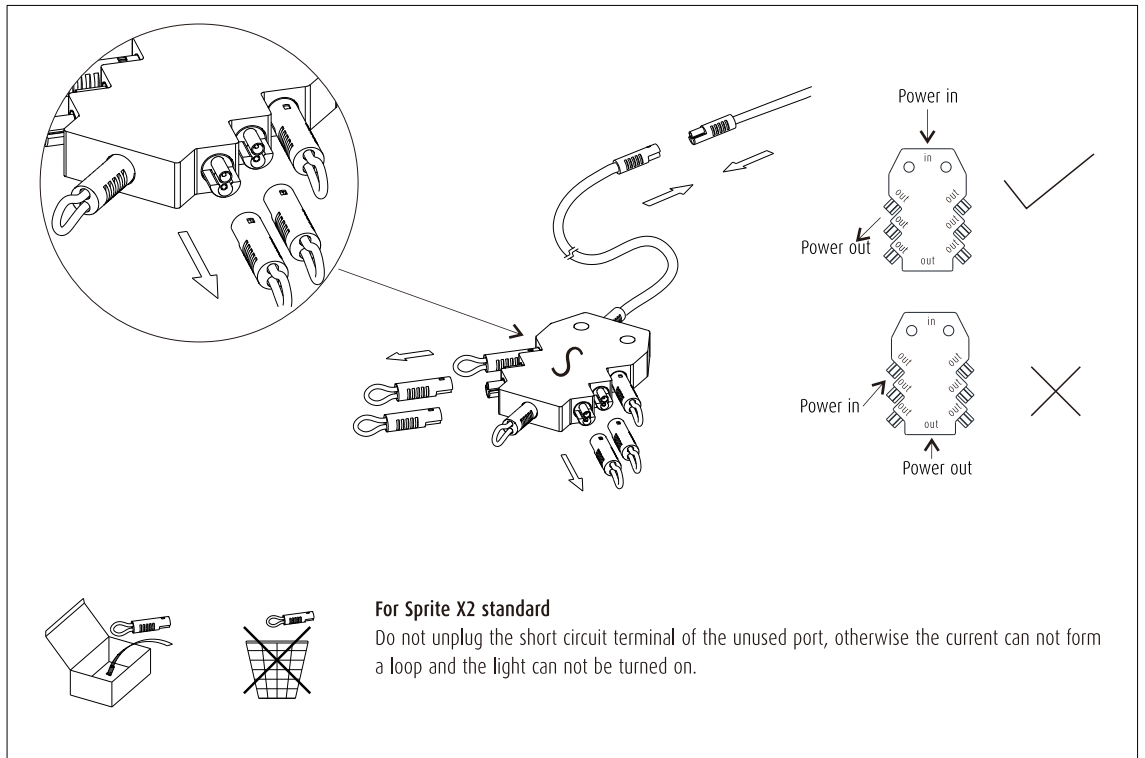
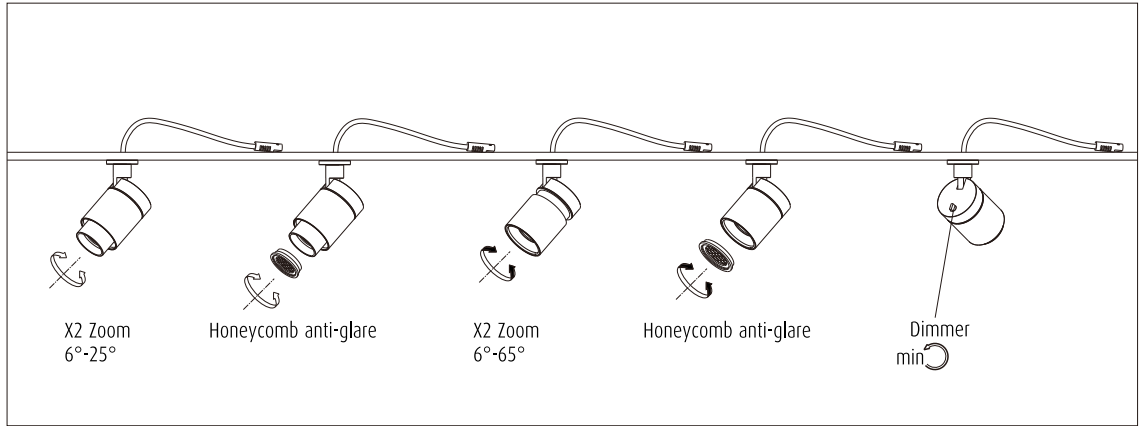

All data, images, and specifications are for reference only and may be changed due to product improvement without prior notice.

More details at www.akzu.com

akzu Installation instruction

for Sprite X2 series Surface mounting

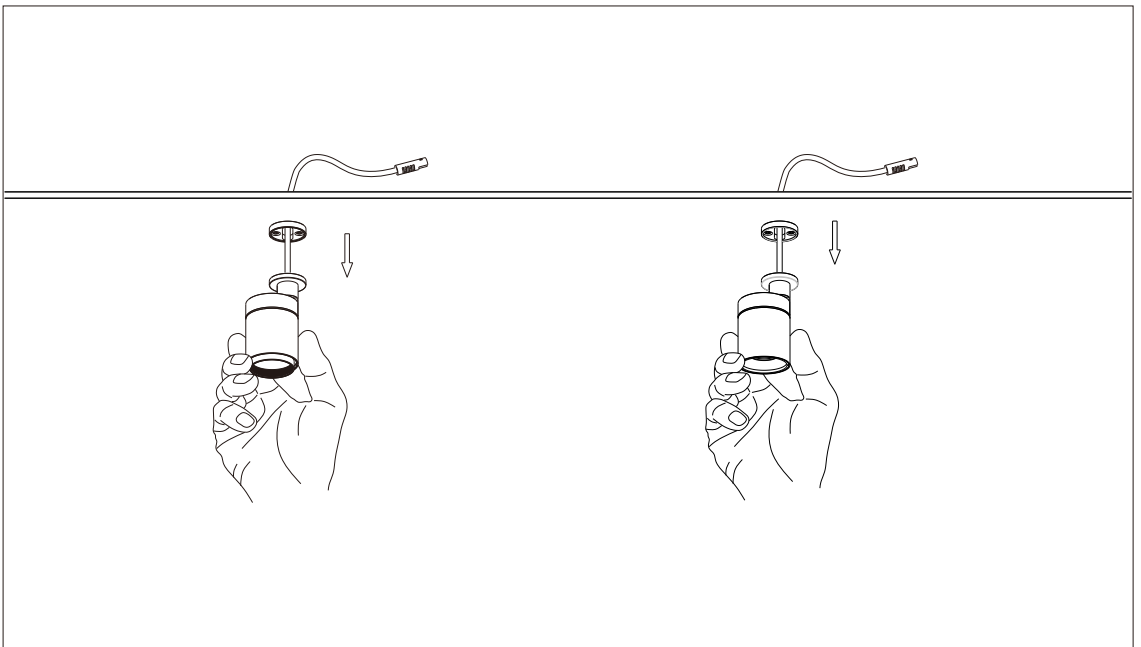
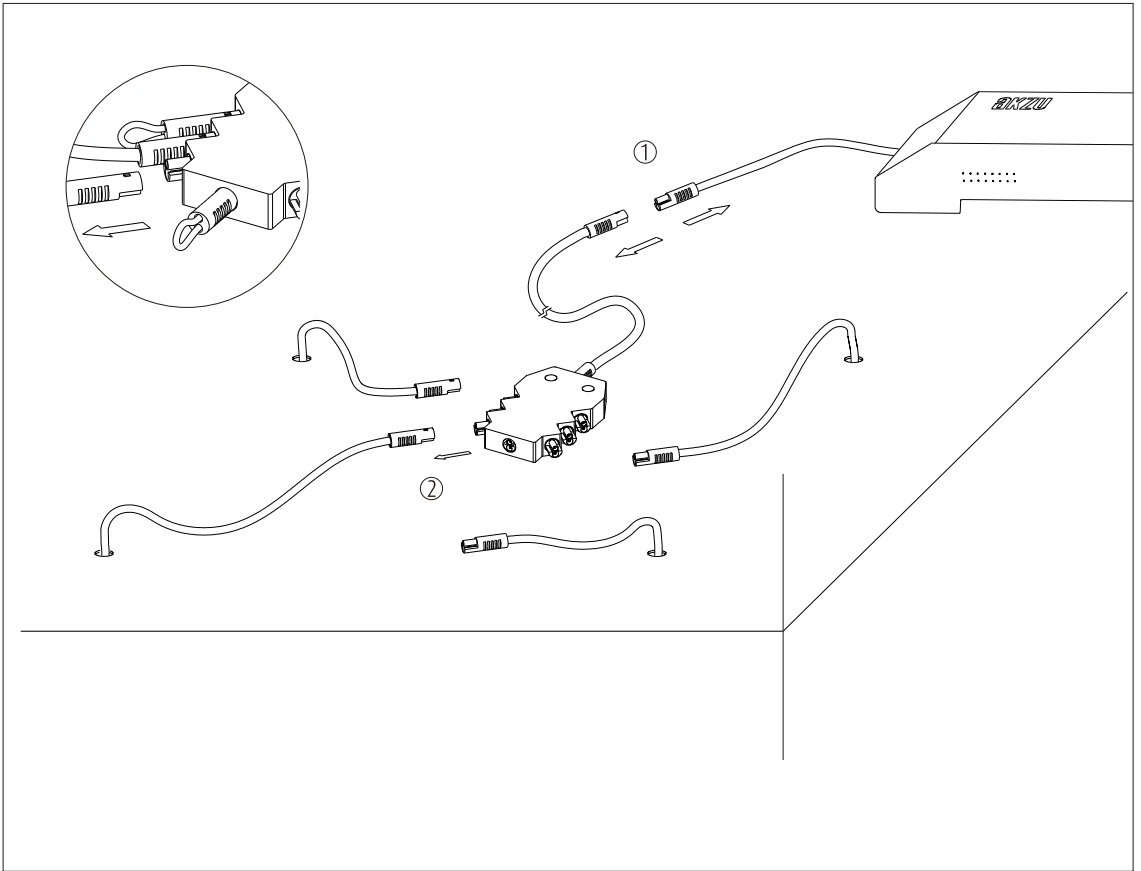
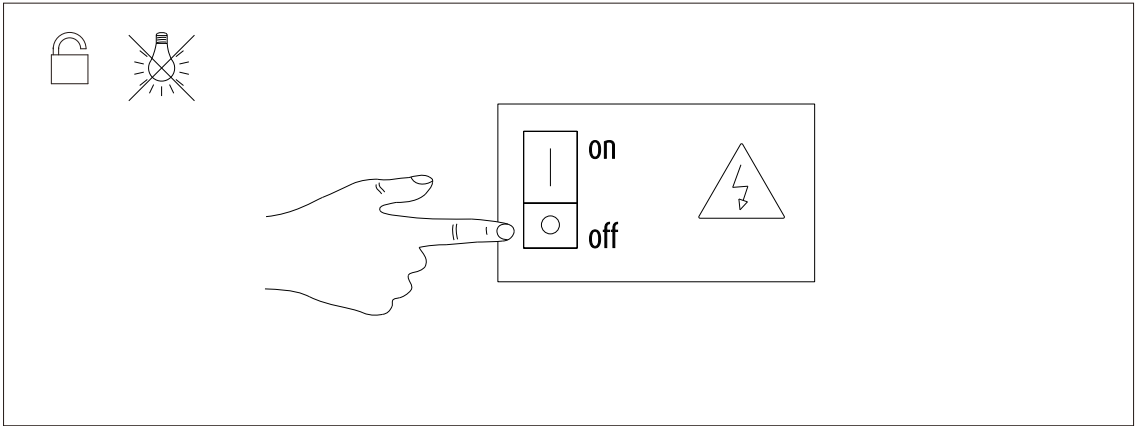

All data, images, and specifications are for reference only and may be changed due to product improvement without prior notice.

More details at www.akzu.com

AKZU Installation instruction

for Sprite X2 series Surface mounting

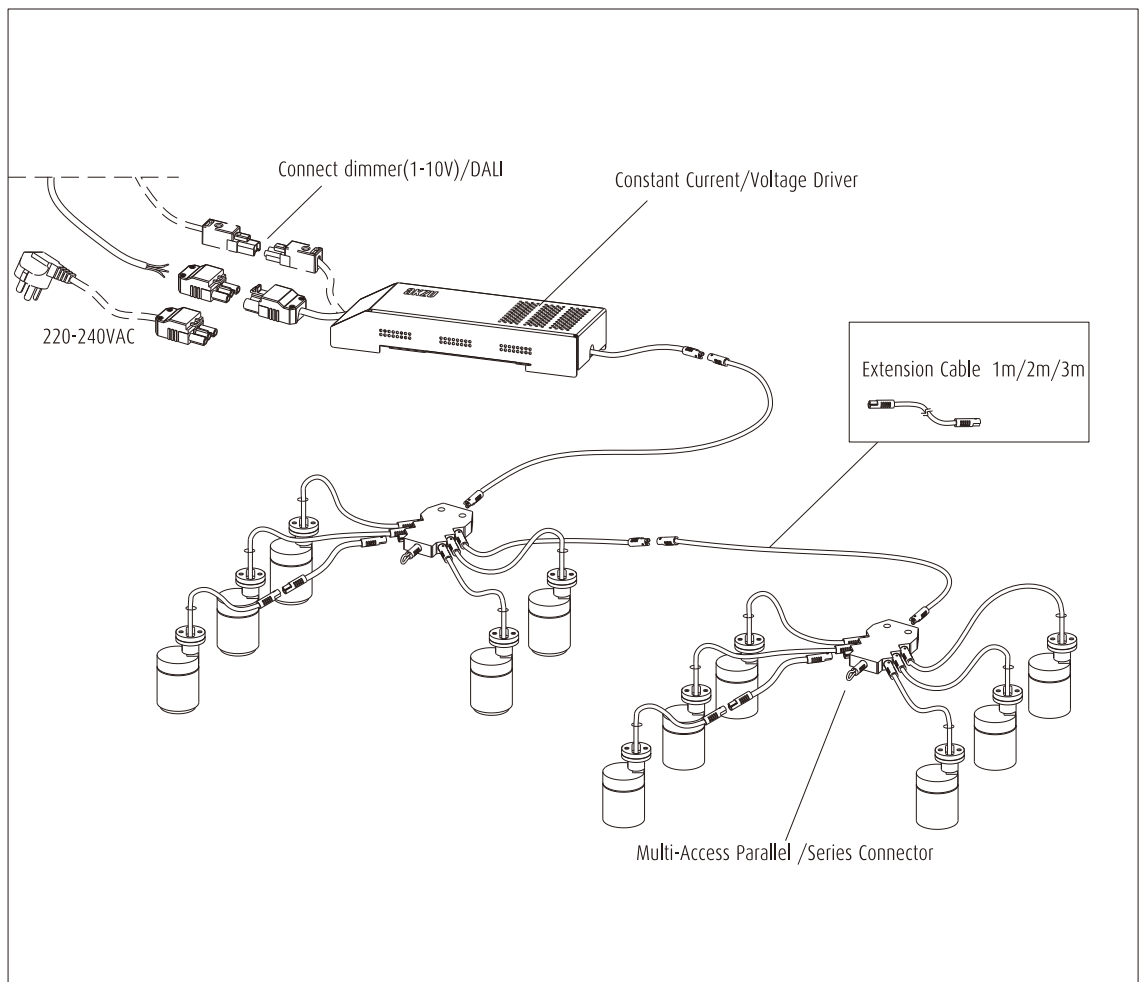
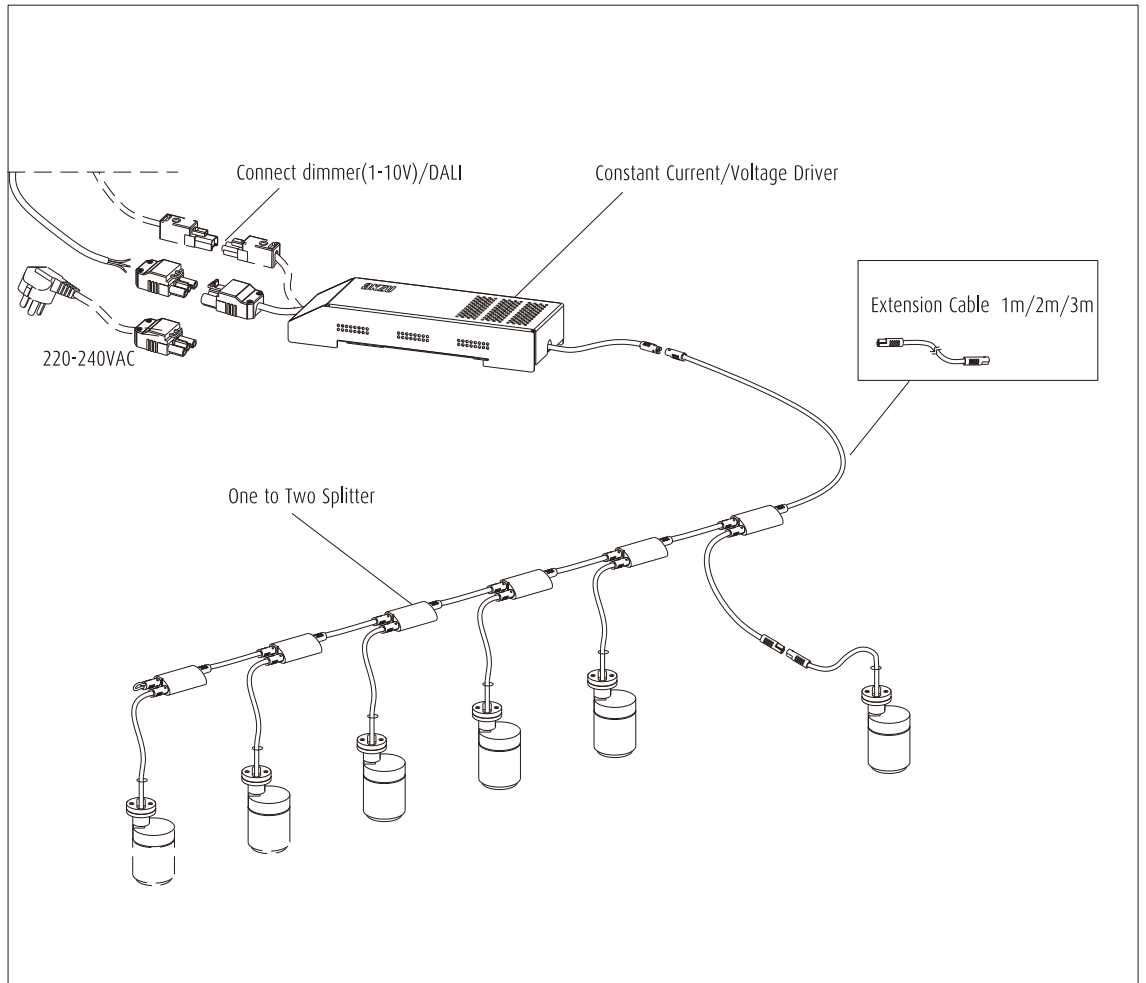

All data, images, and specifications are for reference only and may be changed due to product improvement without prior notice.

More details at www.akzu.com

AKZU Installation instruction

for Sprite X2 series Surface mounting

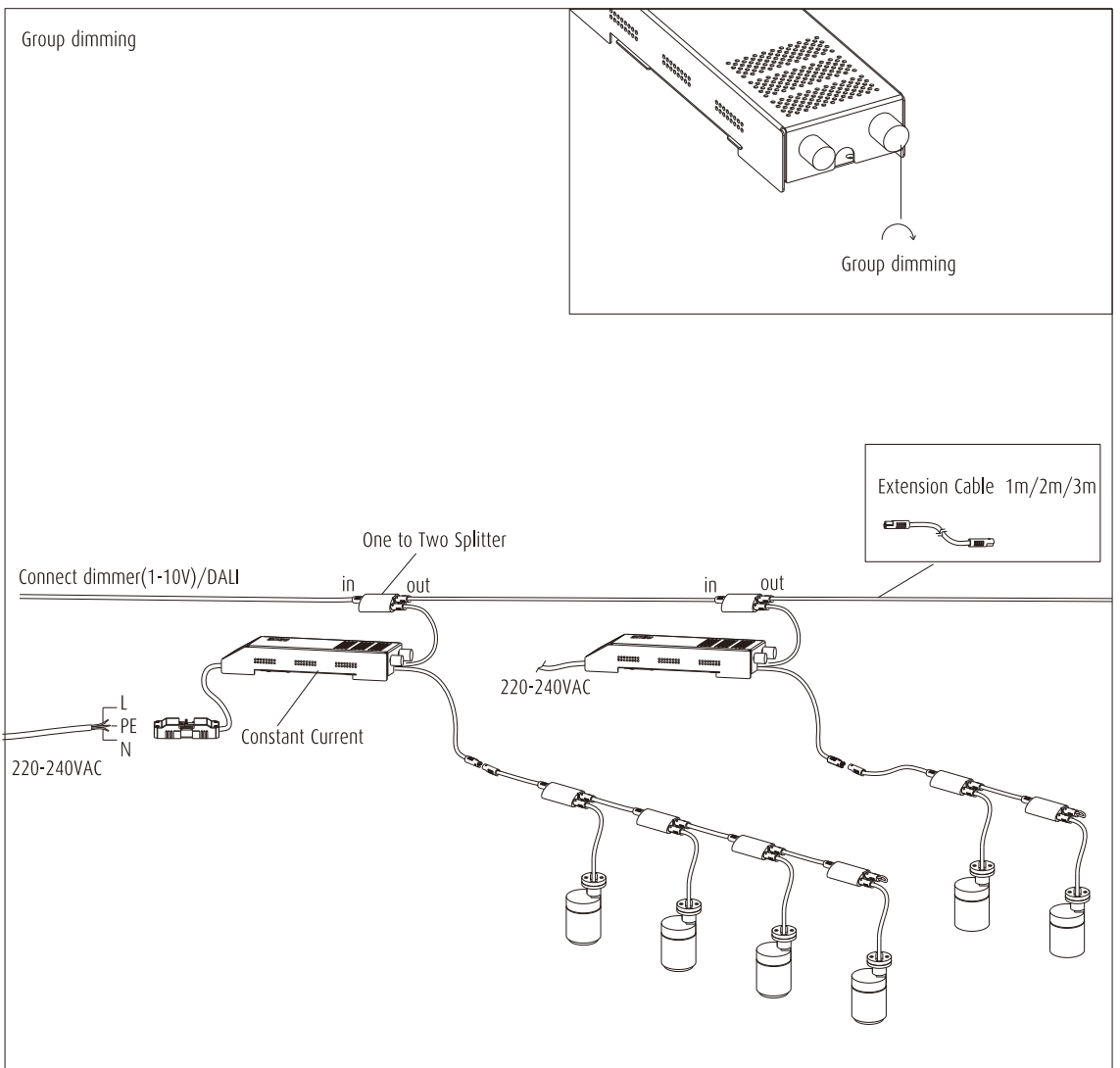
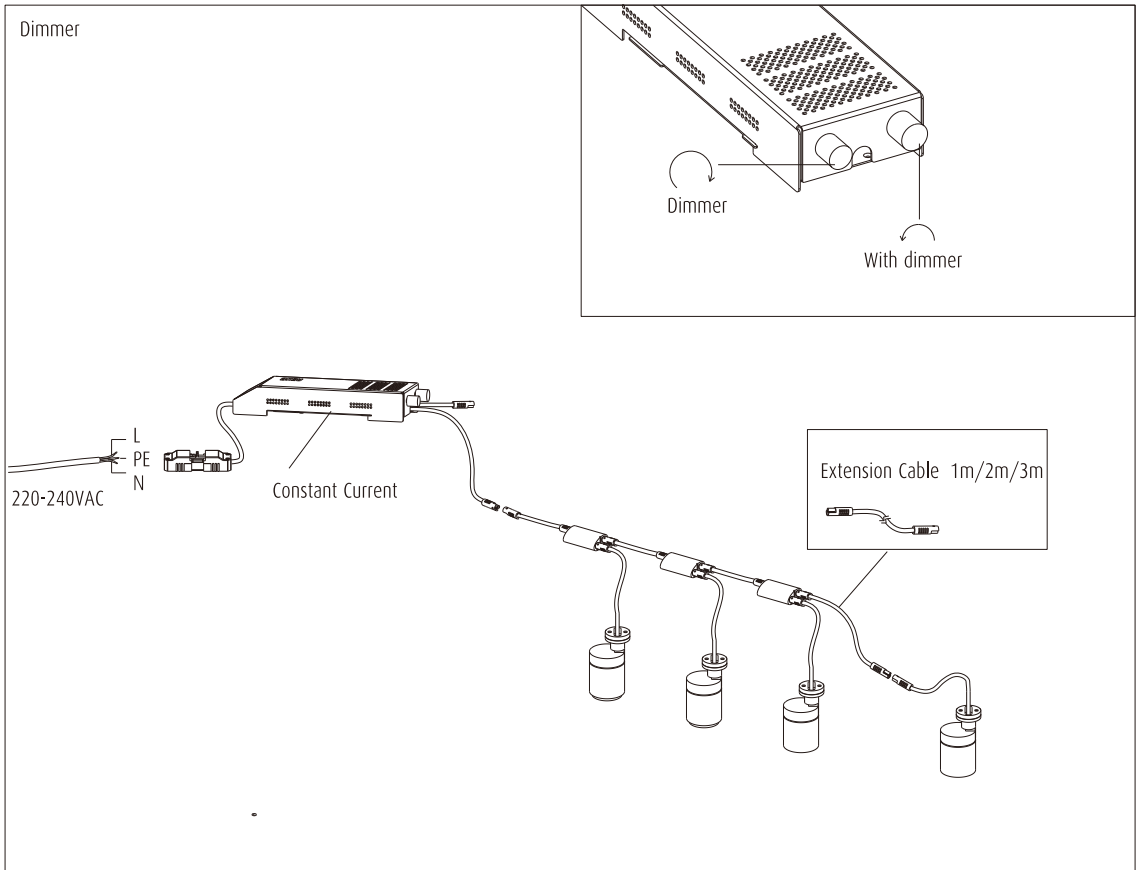

All data, images, and specifications are for reference only and may be changed due to product improvement without prior notice.

More details at www.akzu.com